

BM14C



- Stainless steel IP68 compression load cell
- Hermetically sealed
- Suitable for vehicle and hopper scales and vehicle testing facilities
- Built in surge arrestors
- High accuracy
- Current calibrated (sc-option)



Available models

Capacity	Accuracy	Full article description
0.5 t	C3 Excluded from OIML	BM14C-C3-0.5t-15B
1.0 t	C3 Excluded from OIML	BM14C-C3-1.0t-15B
2.0 t	C3 Excluded from OIML	BM14C-C3-2.0t-15B
3.0 t	C3 Excluded from OIML	BM14C-C3-3.0t-15B
5.0 t	C3 Excluded from OIML	BM14C-C3-5.0t-15B
10 t	C3/C4	BM14C-C3/C4-10t-15B
20 t	C3/C4	BM14C-C3/C4-20t-15B
25 t	C3/C4	BM14C-C3/C4-25t-15B
30 t	C3/C4	BM14C-C3/C4-30t-15B
40 t	C3/C4	BM14C-C3/C4-40t-15B
50 t	C3/C4	BM14C-C3/C4-50t-15B

Specification

Accuracy class		C3	OIML R60 C3	OIML R60 C4
Output sensitivity (= FS)	mV/V	2.0 ± 0.002		
Maximum capacity (E _{max})	t	0,5, 1, 2, 3, 5	10, 20, 25, 30, 40, 50	
Maximum number of load cell intervals (nLC)			3000	4000
Ratio of minimum LC verification interval Y = E _{max} / V _{min}			10000	15000
Combined error	%FS		± 0.023	± 0.0174
Minimum dead load	t		0	
Safe overload	of E _{max}		150 %	
Ultimate overload	of E _{max}		300 %	
Zero balance	%FS		± 1.0	
Excitation, recommended voltage	V		5 ~ 12(DC)	
Excitation maximum	V		18(DC)	
Input resistance	Ω		700 ± 7	
Output resistance	Ω		703 ± 4	
Insulation resistance	MΩ		≥ 5000 (50VDC)	
Compensated temperature	°C		-10 ~ +40	
Operating temperature	°C		-35 ~ +65	
Element material			Stainless steel	
Ingress protection (according to EN 60529)			IP68	
ATEX classification (optional)		II1G Ex ia IIC T4	II1D Ex iaD 20 T73°C	II3G Ex nL IIC T4

Dimensions in mm

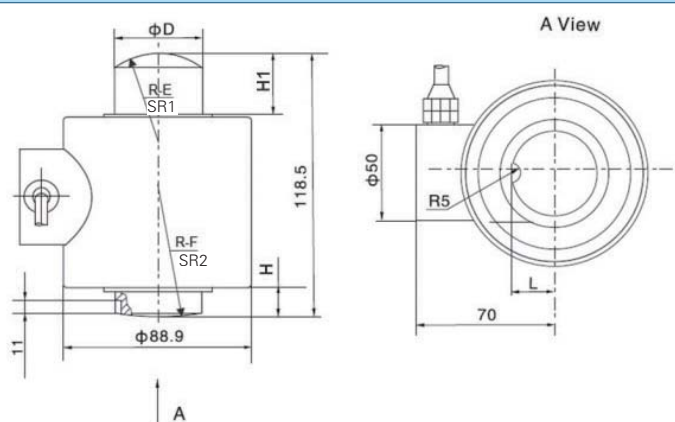

Dimension Capacity	ΦD	L	SR1	SR2	H	H1
0.5-5t	40 (1.57)	22 (0.87)	25 (0.98)	150 (5.91)	14 (0.55)	31.5 (1.24)
10-30t	40 (1.57)	22 (0.87)	37.5 (1.48)	150 (5.91)	14 (0.55)	31.5 (1.24)
40-50t	50 (1.97)	27 (1.06)	200 (7.87)	200 (7.87)	21 (0.83)	24.5 (0.96)

Wiring

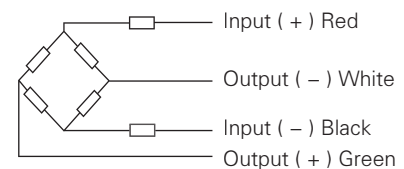

- Shielded, 4 conductor cable.
- Cable diameter: Φ5mm
- Standard cable length : 15m
- Shield not connected to element